

DOIGT DE GANT A VISSER MECANOSOUE
SCREW-IN FABRICATED THERMOWELL
Type TWV

Caractéristiques/Features: **TYPE TWV**

Matière/Material:.....Inox / SS 316 L, 304 L, 316Ti,....
 Longueur/Length U(mm):.....30 mm, 80 mm, 130 mm, 180 mm, 230 mm, 280 mm...
 Diamètre D1 /Diameter D1.....9x7 mm, 10x8 mm, 12x10 mm, 13.5x8.9 mm

Diamètre/Diameter:.....SW= Exa 27 mm (SW27) R2=1/2"
 SW= Exa 32 mm (SW32) R2=3/4"

Raccordement instrumentation R1:.....1/2"GC - 1/2"NPT

Instrument connection R1

Raccordement process R2:.....1/2"GC/NPT ou/ou 3/4"GC/NPT

Process connection R2

Options:.....Plug and chain / Bouchon et chanette

Certificat Matière /Material certificate 3.1B

Test Hydrostatique /Hydrostatic test

Autre sur demande /Other on request

Plan / Drawing

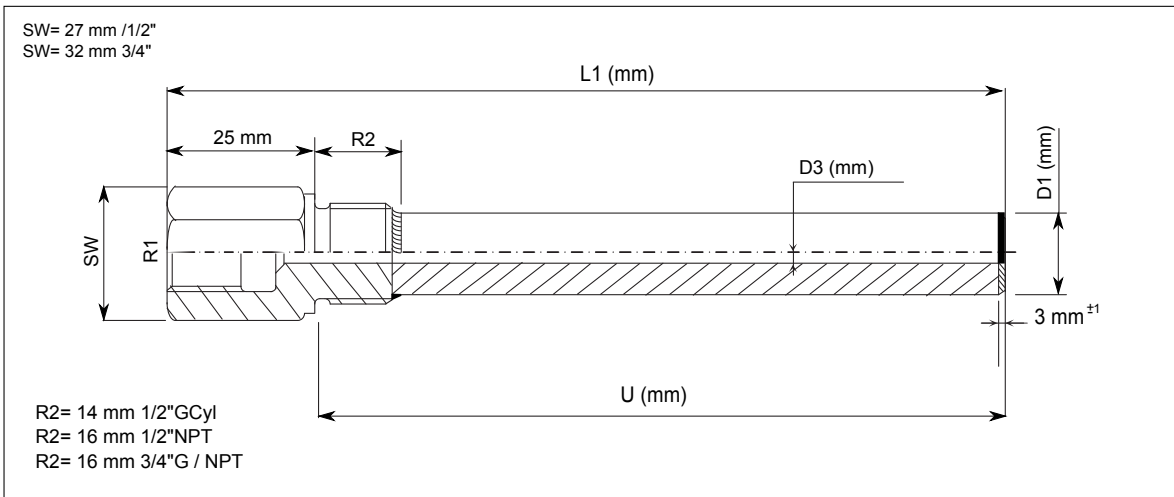

Codification / Order code

